

Tipo "W" (Pinos)

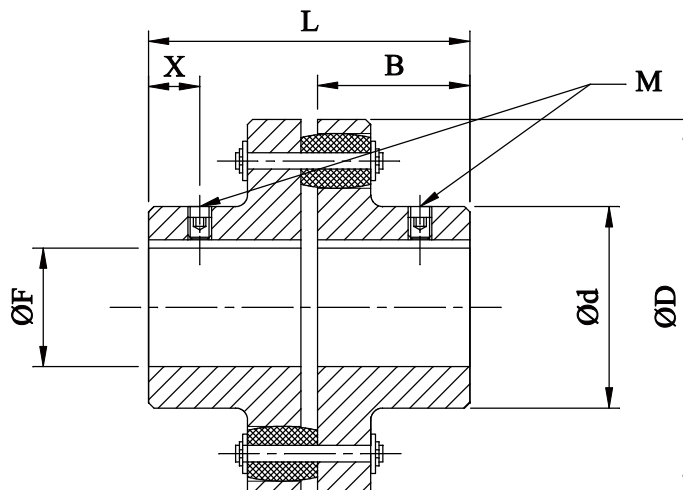

Tamanho W	Ø F (Máx.)	L	X	B	Ø D	Ø d	Rosca M	Mt (Kgfm)	Peso (Kg)
W-03	38	104	17	50	112	58	M8	15	3,0
W-04	42	114	18	55	125	68	M10	23	4,5
W-05	48	124	18	60	140	74	M10	38	6,5
W-06	55	144	23	70	160	85	M12	55	10,0
W-07	60	164	28	80	170	98	M12	90	13,0
W-09	80	197	32	95	225	125	M14	180	26,0
W-11	110	237	42	115	270	170	M14	360	50,0
W-13	150	300	50	145	360	220	M16	720	108,0
W-15	160	380	62	185	450	270	M16	1430	215,0

Tipo "ZA" (Cruzeta)

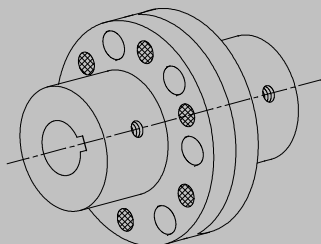
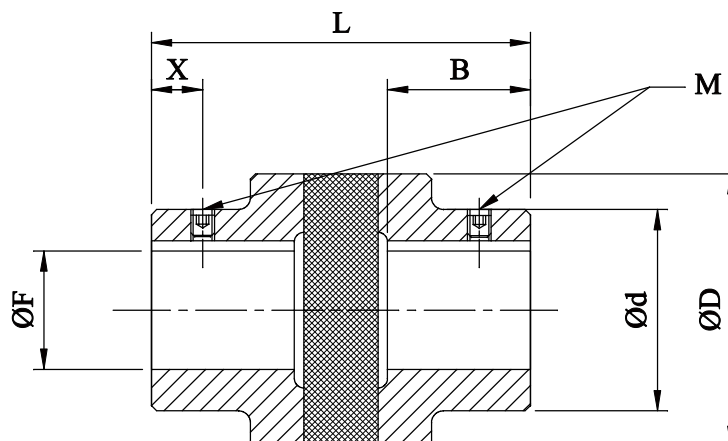
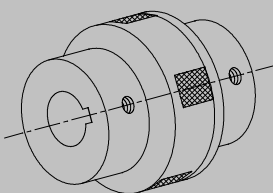

Tamanho ZA	Ø F (Máx.)	L	X	B	Ø D	Ø d	Rosca M	Mt (Kgfm)	Peso (Kg)
ZA0	11	46	7,5	17,0	25,0	20,0	M5	0,4	0,1
ZA1	20	70	8,5	25,0	46,0	35,0	M6	0,8	0,5
ZA2	25	86	11,5	30,0	59,5	42,5	M8	1,4	0,7
ZA3	38	105	11,5	38,5	73,0	66,0	M8	3,0	2,0
ZA4	45	130	15,0	50,0	95,0	82,0	M8	6,0	3,5
ZA5	55	160	19,0	61,5	115,0	85,0	M8	12,0	6,5

MACOPEMA INDÚSTRIA E COMÉRCIO LTDA.

AV. Dr. JOSÉ DE PAULA EDUARDO,1400

MONTE ALTO - SP CEP 15910-000

FONE/FAX (16) 3244-0707

e-mail: macopema@macopema.com.br

OBS: INFORMAÇÕES SUJEITAS A ALTERAÇÕES SEM AVISO PRÉVIO

CAT. 009 / ABRIL 05